

are recognition software to read a solid to
ology and shape of the solid.

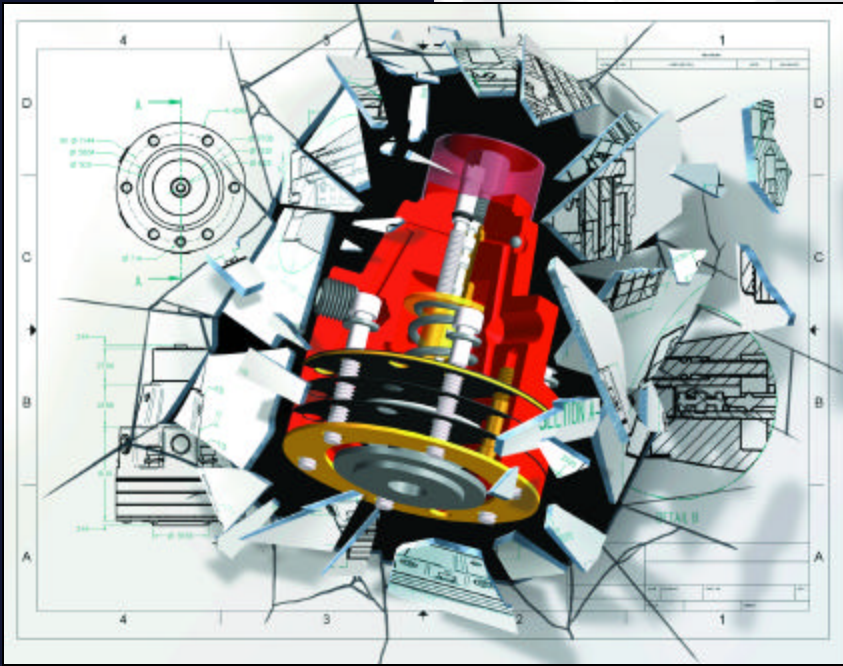

SOLID EDGE



Moving From 2D to 3D CAD

*The productivity
and business
advantages*

**Unigraphics
Solutions®**

Moving from 2D to 3D CAD

The productivity and business advantages

The primary challenges of manufacturing companies are to design better products, in shorter time frames, at lower cost. The value that manufacturers offer their customers is continually threatened by competitors who are racing to deliver higher-quality products with more features at lower prices. In an effort to better respond to market pressures, manufacturers are realigning their computer-aided design technology to better achieve their business objectives. Currently the most remarkable trend in this realignment is the move from 2D CAD design techniques to design processes that take advantage of 3D solid modeling.

Why this strong move from 2D to 3D design? This paper examines the limitations of 2D design processes and outlines the engineering productivity and business advantages of product development using 3D solid modeling technologies.

Introduction

Two-dimensional engineering drawings have been a staple of the design process since the late eighteenth century, when the principles of orthographic projection and descriptive geometry were first developed and applied to engineering problems. During the period of explosive industrial growth in the late nineteenth and early twentieth centuries, drawing standards were developed that established engineering drawings as critical business documents for manufacturing companies.

As we enter the twenty-first century, 2D drawings still play an important role in engineering practice, and in many cases serve as the definitive design documentation that guides manufacture, fabrication, and assembly of products. The ability to

use and interpret 2D engineering drawings remains an essential element of the professional literacy of the engineer.

Over the past three decades, computer-aided design (CAD) technology virtually eliminated traditional manual drafting tools and has helped manufacturers realize manifold increases in productivity for creating engineering drawings. With lower costs and universal accessibility to computer-aided tools, most all manufacturing firms have some type of CAD systems installed – a 1998 survey conducted by *Mechanical Engineering* magazine indicates that 96% of mechanical engineering professionals currently use a CAD system.

A 1999 study of CAD/CAM practices by the Dataquest industry research firm indicates that more than half of surveyed companies still use 2D techniques as the main design method, though 75% responded that 3D would be the main design technique in two years.

Despite the advent of affordable and easy-to-use 3D solid modeling technology, a majority of manufacturing firms still base their design processes on 2D CAD techniques and drawing data. A 1998 survey by *Computer Aided Engineering* magazine revealed that more than 60 percent of CAD engineering work is done in 2D. But engineering and manufacturing businesses seeking order-of-magnitude reductions in their design cycles are quickly turning to 3D CAD tools – the same survey indicates that

manufacturers' CAD purchase intentions overwhelmingly favor 3D CAD over 2D CAD, by almost a three-to-one margin.

Similarly, a 1999 study of CAD/CAM practices by the Dataquest industry research firm¹ indicates that more than half of surveyed companies still use 2D techniques as the main design method, though 75% responded that 3D would be the main design technique in two years.

¹Dataquest, *End-User Analysis: Mechanical CAD/CAM/CAE From the User Viewpoint*, 1999

The limitations of 2D design

If most manufacturing companies are moving to 3D design techniques, why are so many still using 2D for mainstream product development? In the Dataquest study, the top reason for remaining with 2D CAD is simply that 2D CAD is adequate to meet the company's design needs, according to more than a third of the respondents.

While most companies are comfortable with time-honored and production-proven 2D design methodologies, product development processes that rely on 2D CAD as the primary design tool have critical limitations that unnecessarily extend design cycle time, compromise product quality, and increase engineering and manufacturing costs. These limitations can be attributed to the nature of 2D design data and 2D CAD tools.

Inability to easily assess fit and tolerance problems in 2D

Design engineering for the typical product begins with a layout concept that describes the overall product component and subassembly interfaces and working envelopes. Captured in a 2D drawing, this layout is of limited value in solving problems in the early stages of design, when it is easiest and least expensive. While a 2D layout drawing may be

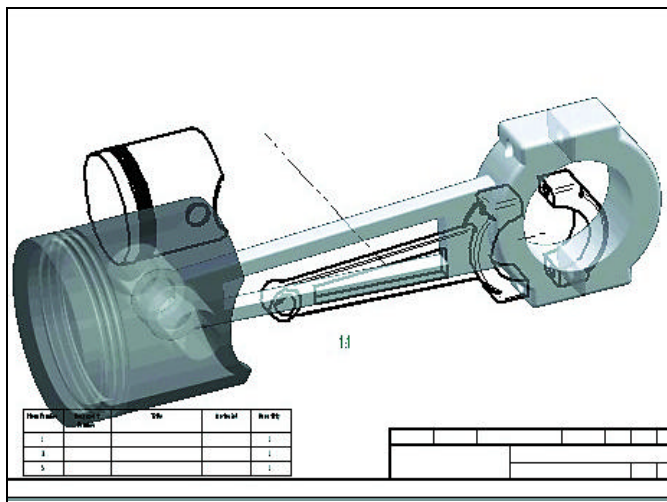

somewhat useful in determining general component and subsystem arrangement, it is woefully inadequate in helping engineers visualize the 3D fit, interface, and function of assembly components. The inadequacy of 2D in solving assembly problems is especially acute in assemblies with many moving parts, where reliance solely on 2D design capture introduces a multitude of design errors.

2D design complicates the checking process

Because of the limitations of 2D drawings in assessing assembly fit and tolerance stack ups, most assembly designs that are developed with 2D design tools require a lengthy, laborious, and error-prone drawing checking process. Drawing checkers often must spend days checking fit and tolerance dimensions between part drawings to assure assembly quality, even on assemblies with only a few parts. The checking process is compounded when drawings are produced by different drafters using different datums and dimensioning parameters. Red-lined drawings go back to designer or drafter for corrections and then back to checker for final check and approval, which may extend the design cycle significantly, especially for complex assemblies with hundreds or thousands of parts.

2D design demands physical prototyping

Because 2D drawings do not fully capture and communicate details of actual three-dimensional assemblies, 2D design forces development teams to rely on physical assembly prototypes to reveal fit and interference problems. With 2D design techniques, much of the assembly engineering is actually accomplished by building up and tearing down a physical model – the only way to spot most interference and clearance problems. This reliance on a physical model adds significantly to the product development cycle. Not only are there lead times for each component prototype, but also the assembly mock-up and problem solving times, along with the design changes, rework, and re-engineering that are inevitable with this approach.

Inefficient drawing creation with 2D CAD systems

Within the typical 2D design process, both part and assembly design data is formally captured in 2D engineering drawings. The designer or draftsman creates and details a variety of 2D views of each part, working with CAD commands that control the lines, arcs, circles, dimensions and other primitives of the 2D system. Such primitives are clumsy in that they require the design professional to think and execute the design in terms of low-level drawing elements rather than in design engineering terms. For example, a countersunk hole must be mentally and operationally translated to its equivalent circles, lines and arcs to be rendered in different views in the 2D CAD system.

In addition, 2D CAD systems are notoriously inefficient at creating isometric views and exploded assembly views, where the actual dimensions of the parts do not match the dimensions of the elements in the planar representation because of the perspective of the viewing angle. The difficulty and time involved in creating isometric views with 2D CAD has forced many companies to forego isometric view creation, even though these views may be very valuable in visualizing, understanding, or identifying designs. The same problem is inherent with other drawing views like detail views and section views, where the designer or draftsman must spend significant time determining the details and scales of the views, then create the individual graphic elements that comprise each view. The element-by-element and view-by-view drawing creation process can add significant time and costs to the design of intricate parts or complex assemblies.

Tedium of 2D design changes

Because every design typically requires more than one 2D orthogonal view, and often a variety of auxiliary views like detail or section views, a single part may require the designer to re-create design

details a number of times in a 2D CAD system. This repetition of design data for each view is not only redundant; it also becomes extremely inefficient when changes are made to a design. Each design modification must be implemented in all affected drawing views, a process that is tedious, cumbersome, and time-consuming. Designers must review all affected 2D CAD files and inspect every drawing view and detail, then edit each affected view individually.

Many "new" products are actually derivatives of existing designs that copy most of the existing details but involve some modifications. As with routine design changes, creating derivative products or product families from 2D design data involves going from view to view to view to make revisions that match the new product modifications.

Product development processes that rely on 2D CAD as the primary design tool have critical limitations that unnecessarily extend design cycle time, compromise product quality, and increase engineering and manufacturing costs.

Inability to use 2D design data directly in downstream processes

Two-dimensional design data is of very limited value in a host of corollary engineering and manufacturing processes. Whether the design requires only the simplest calculation of mass properties or full-blown motion or stress analysis, it is difficult or impossible to analyze a 2D design without re-creating design data in

three dimensions. In addition, production cycles for most products include processes that require 3D design data, such as tooling creation and numerical control programming. While engineering drawings of a design may form the basis for all downstream processes, the turnaround times for analysis and manufacturing are inevitably extended whenever design data must be re-created in three dimensions.

Extended engineering analysis turnaround times

The 2D-based design process typically uses engineering rules of thumb that can get designers through many problems, but fall short when hard analysis of possible failure modes is needed. Using

practices based on experience and trial and error, most designers using 2D skip detailed analysis in favor of overdesign. But true design analysis and optimization require sophisticated motion, force, and stress analysis with computer-aided engineering (CAE) tools, which cannot directly use 2D drawing data. Whether companies use CAE analysis in-house or outsource their analysis services, the turnaround is extended by the amount of time it takes to re-create design data in 3D.

Protracted manufacturing cycles

Product development based on 2D CAD must allow additional time for manufacturing, fabrication, and assembly because of the incomplete communication that 2D drawings afford these downstream processes. Whether the product and its components require simple jigs and fixtures or specialized tooling like plastic injection molds, production engineers and toolmakers need additional time to interpret and understand drawings, and also must allow more time for corrections due to missed dimensions or omitted details.

For numerical control machining, only the simplest machined or fabricated parts can be efficiently programmed from 2D design data. Full surface geometry is a minimal requirement for virtually all components produced by 3- to 5-axis machining. With only 2D drawing geometry as input, the numerical control programming function is delayed until the 3D geometry can be created.

Manufacturers using 2D design techniques cannot readily take advantage of rapid prototyping technologies (such as stereolithography or laser sintering) to trim prototype lead times. These technologies require 3D solid geometry as input, which must be created from 2D data before parts can be produced in the rapid prototyping machinery. This additional step adds time and expense to the process and counters the quick turnaround advantages of the rapid prototyping technologies.

Rework for publications and documentation

Two-dimensional engineering drawings may form the basis for some graphics in technical publications and documentation, and may occasionally be used

directly for those purposes. However, in most cases assembly and installation instructions require customized isometric and exploded views. These design graphics are usually created, with significant difficulty, either with the 2D CAD system or with a technical illustration package. Service manuals, marketing documents and product packaging typically cannot directly use 2D graphics from engineering drawings, so the production of product deliverables may be extended for companies using 2D CAD.

Summary: Crawl to market with 2D CAD

While engineering drawings have proven successful in building products for centuries, manufacturing companies who base their product development processes solely on 2D design techniques are crawling to market. Two-dimensional engineering drawings will remain an important form of design documentation for the foreseeable future, but 2D design techniques are inherently more cumbersome and less productive than commonly available alternatives. New, more productive 3D technologies have superseded the inefficiencies of the 2D-based design process, and are establishing new standards for shorter design cycle times, improved product quality, and lower costs.

Removing the barriers to 3D design

As noted above, the most frequently cited reason for not using 3D design techniques – that 2D is adequate – may be a dangerous pretext for manufacturing companies. Indeed, the other main reasons cited for not using 3D – that 3D systems are difficult to learn and use, that 3D systems are too expensive, and that 3D design is not compatible with current design work – are likewise hollow excuses in light of the current 3D design tools and techniques that have gained mainstream acceptance.

Unigraphics Solutions' Solid Edge is leading the new breed of 3D solid modeling tools that are bringing greater productivity to former 2D CAD designers and to companies using 2D-based design processes. Solid Edge was developed specifically to address the inherent inefficiencies of 2D design and to remove

all the traditional barriers to the adoption of 3D solid modeling.

Ease of learning, ease of use for 3D solid modeling

With its initial launch in 1996, Solid Edge introduced revolutionary innovations in interface design and user operation that changed forever the ease-of-use paradigm for 3D design. Every subsequent release of the software has included significant enhancements aimed at making 3D solid modeling easier to learn and more efficient in the design process.

Independent studies of software usability have confirmed that Solid Edge is indeed the most user-friendly and productive solid modeling design tool available.

Low entry cost for 3D design

In addition, Solid Edge was developed from the ground up as a Windows-based application that runs on inexpensive Intel processor-based workstations, so that manufacturing companies need not make staggering investments to gain access to 3D design capabilities. In a recent study of the cost of CAD by the TechniCom industry research firm, Solid Edge ranked lowest in five-year cost of ownership in multiple-seat configurations of the many 3D systems included in the evaluation.²

Compatibility with 2D design

Solid Edge also challenges the objection that 3D design is not compatible with current design work – it includes built-in tools that address the needs of design professionals currently using 2D CAD. Solid Edge can read and write files in all the popular 2D CAD formats, and can even employ existing 2D CAD data directly in the solid modeling process. The software includes demonstrations, tutorials, and help aimed at easing the transition to 3D for 2D users, and provides a complete 2D drafting system so

companies can use familiar, comfortable 2D design techniques while migrating to 3D-based design processes. With Solid Edge, companies don't have to throw away their legacy data or their existing processes and start from scratch – they can instead grow and evolve their current design practices to meet the needs of the future.

Thousands of companies have already recognized that with Solid Edge, there are no more excuses for not adopting 3D solid modeling design techniques. Companies who have made the transition from 2D to 3D are realizing significant time-to-market and productivity benefits of 3D CAD. Many of their experiences are related in the review of 3D CAD benefits that follows.

The benefits of 3D CAD

Three-dimensional solid modeling is no Holy Grail for manufacturers – rather, it is a mature technology that has practical benefits in virtually all phases of the product development process. Product definitions captured in 3D solid geometry provide superior communication of design intent, not only among the members of a product design team, but also throughout the engineering and manufacturing organization, the larger enterprise, and the supply chain.

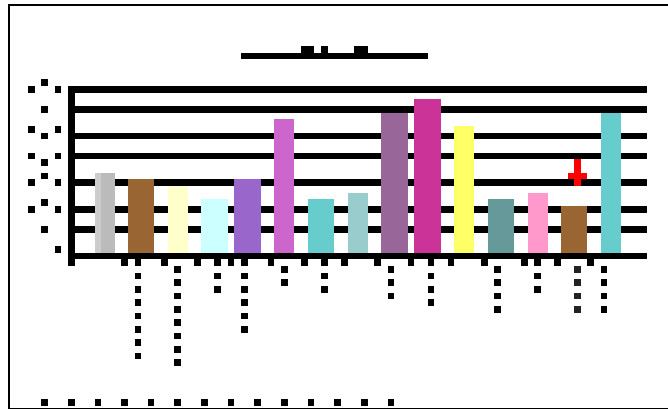

Faster design capture with solid modeling

Parametric, feature-based solid modeling with Solid Edge is a very intuitive method of design capture

²TechniCom, Inc., *An Analysis of Pricing and Offering Conditions of Principal Participants in the Mechanical CAD/CAM Industry*, 8th Edition, published September 1999.

which uses terms, concepts, and commands that are inherently more familiar to design professionals than the placement commands for drawing primitives in the typical 2D CAD system. With ease-of-use innovations like STREAM technology, which uses inference logic to optimize CAD efficiency by improving the speed and effectiveness of user interactions, Solid Edge enables designers, engineers, and drafters to be comfortable and productive with powerful solid modeling design tools that are easy to master and control. The result is faster design capture – in complete, precise 3D solid models – than design capture in 2D drawing geometry.

Case study. "Working in 2D requires the operator to follow a laborious process of placing and trimming a series of elements until the desired net shape is produced," says Howell N. Cornell, director of engineering/research at TRACO, a leading manufacturer of commercial and residential replacement windows. "This is often very time-consuming, especially if revisions are necessary later, which is often the case in the design development environment." As an example, Cornell cites a simple extrusion that required 25 commands and 45 picks to create with AutoCAD. Dimensioning it required 10 commands and 20 picks, for a total of more than 100 operations.

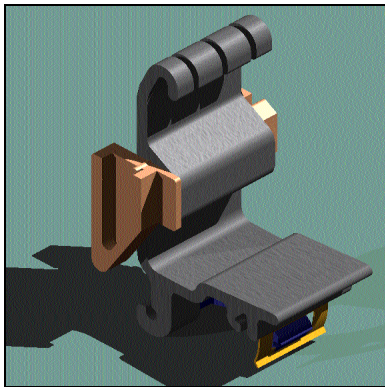

and 12 picks, for a total reduction in operations of 51 percent.

Faster drafting with solid modeling

3D solid modeling can eliminate the need to create drawings view by view from low-level 2D drawing elements. With a solid modeling system, companies

With Solid Edge, creating new designs has become much simpler. The same extrusion that took more than 100 operations in AutoCAD is created with three commands and 32 picks in Solid Edge. It is dimensioned with two commands

can make drawings by simply defining views of the solid model – the graphics of the planar drawing views are created automatically based on the 3D part and assembly geometry.

Automated view layout greatly simplifies the process of creating orthographic views, auxiliary and detail views, and isometric views. Because the drawings are actually references to a master solid model, there is no need to revise drawings on a view-by-view basis when the design is modified – the views update automatically when changes are made to the geometry of the solid model.

Case study. Efficiencies provided by solid modeling, such as the speed of generating drawings, have reduced Kaiser Optical Systems' development cycle by 20 to 30 percent compared to the previous 2D CAD process. The company's experience with the software so far indicates a 20 to 30 percent reduction in the time needed to create a model and produce drawings compared to using AutoCAD or CADKEY. "Drafting productivity has improved significantly," says Joe Slater, manager of new product development. "Once the model is made, the drawings come out at least twice as fast." Also, when changes to a design are needed, they now require about two-thirds the time they did previously due to the ease of modifying a Solid Edge model.

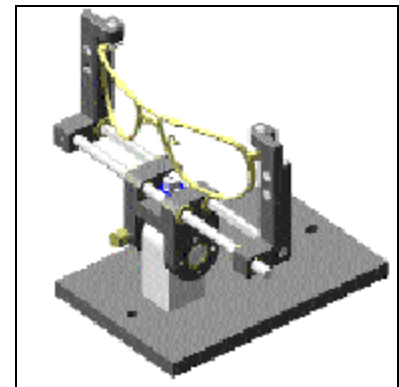

Better visualization with 3D solids

Companies are moving away from sharing design information using 2D paper drawings. With 3D solid models of parts and assemblies, the design team and downstream users of the design information now see exactly what it is and how it fits in the assembly structure before anything is actually built, ensuring that the product is manufacturable the first time. The superior visualization provided by solid assembly models also allows engineers to visually evaluate fits,

interferences, and working envelopes, quickly and with great accuracy.

Case study. W. F. Mickey Body Company, Inc. didn't switch to solid modeling lightly. Officials of the company, which manufactures aluminum truck bodies and trailers, would consider a move to solids only if it was both cost-effective and significantly superior to the 2D design approach. One of the first benefits of solid modeling that designers noticed was the ability to evaluate assembly integrity. The various parts of truck bodies are all eventually

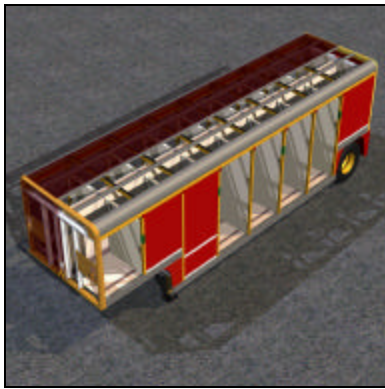

joined during assembly. But until the move to solid modeling, designers had to work with multiple 2D views without the ability to see how all the pieces fit together. With an assembly image on the screen, fit problems are detected before they reach

production assembly. Designers are also finding ways to improve products that were not evident before. "Being able to see all of the parts instead of multiple 2D snapshots enables us to see possible modifications to one part of assembly that might totally eliminate the need for another," says John Hargett, manager of research and design. "These things weren't nearly as obvious when we worked with 2D drawings."

3D modeling reduces design errors

With the more complete visualization and geometric definition that 3D solid modeling affords, companies can significantly reduce the number of design errors, as compared with 2D design techniques. This error reduction eliminates the time and expense of rework, re-engineering, engineering change orders, and iterative cycles for analysis, prototyping, tooling, manufacturing engineering, and other related product development activities.

Case study. Dayton Systems Group Inc., a Dayton, Ohio-based machinery supplier to the can industry, designed a new machine in half the time it would

have taken using 2D CAD. The ability to digitally assemble the machine, which automatically bags can lids and places them on a pallet, ensured that all 4,000 components interacted perfectly when the first prototype was built.

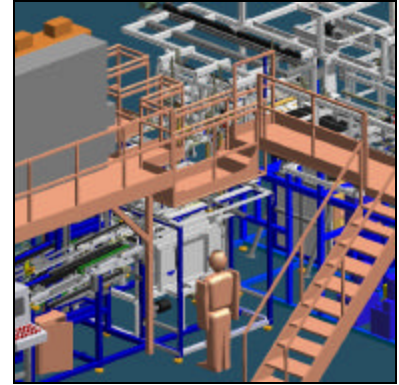

"We might have designed this machine in the same amount of time with 2D CAD, but because of all the moving parts there would have been many errors," says vice president Steve Cook. "Fixing those errors would have taken us at least another year. By building the machine digitally using the software's assembly modeling capability, we knew everything would fit. That was much more efficient than tearing apart a prototype to make it work."

3D design reduces or eliminates physical prototypes

The 3D part and assembly modeling functions in Solid Edge enable manufacturers to identify and solve almost all form, fit, and function problems with virtual assembly models, prior to actually building prototypes. With 3D solid part models, designers can automatically determine mass and physical properties of their designs, such as weight, center of gravity, and moments of inertia, without manual calculation. For assembly designs, Solid Edge enables engineers to design in the context of the assembly, using the geometry of neighboring or interfacing parts to ensure correct-by-design fit of assembly components. This "virtual assembly" capability is an accurate and complete geometric representation that provides all the advantages of the physical assembly prototype for solving assembly design problems. Companies using solid assembly modeling can dramatically reduce or even eliminate physical prototypes and their associated costs and lead times. With 3D solids, prototypes function in the design process more as pilot builds or even as finished products.

Case study. Value Plastics, a Colorado-based manufacturer of precision plastic tubing components, was racing to develop a working

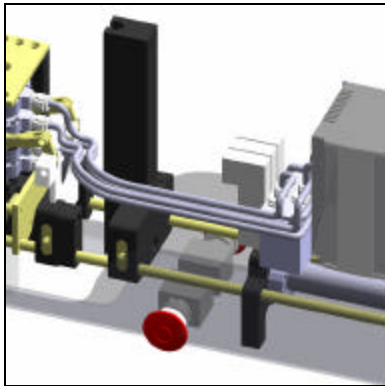

prototype of a tube setting machine for a trade show. The ability to visualize the machine's 50 individual components as solids enabled engineers to fine-tune their designs as they created the CAD models. Then, as the components were assembled on

screen, potential interferences and clearance problems were spotted and fixed. The result was a prototype that behaved just like a finished product.

"If we had tried to do this with 2D CAD, we either would have missed the deadline, or we would have had dedicated a lot more man hours in testing and in the tool room," says Bruce Williams, chief engineer at Value Plastics. "Either way, without solid modeling, our prototype would not have looked as good or performed as well as it did. With the better visualization that solid modeling provides, we could see things about the individual components that we might not have noticed working in 2D. And putting components together and seeing how they fit in relation to each other was a tremendous time saver. Without Solid Edge, we would have needed to do a great deal of prototype testing. Instead we found problems and solved them on-screen, saving us at least six weeks."

Easy design changes in 3D solids save time, improve quality

The ability to quickly and easily make design changes and variations is one of the key advantages of parametric solid modeling. Because parts and assemblies are defined in Solid Edge in parameterized features and associative relationships, designers can rapidly effect changes. Instead of creating new geometry from scratch to capture a design change, the designer can simply alter a dimension value, modify the shape of a defining profile, or redefine a design relationship to create a

new variation of the design. The solid geometry of the part or assembly automatically regenerates in a fashion that preserves all captured design intelligence and behaves in a predictable way. This capability not only saves time and expense when implementing engineering change orders; it also helps designers improve the quality of designs by evaluating more iterations in a given time frame.

Case study. MPB Technologies, Inc., a Canadian high technology firm, used Solid Edge's family of parts capability to quickly generate 60 different product configurations from a single master design of a fiber amplifier product. Scott

Sumner, manager of new product development, created an assembly of 25 components linked to a matrix of driving dimensions stored in Microsoft Excel. When Sumner changed the spreadsheet, Solid Edge automatically generated new models, new 2D drawings, new assembly drawings and new bills of material. In a matter of minutes, Sumner can create a new configuration and print a complete catalog of more than 100 component parts. Sumner recommends Solid Edge's family-of-parts modeling wholeheartedly. "Anyone trying to design more than 3 configurations without it is wasting time and money."

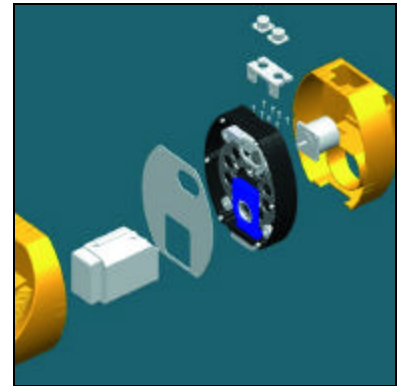

3D CAD accelerates other development processes

Because they provide precise and complete geometric descriptions of designs, 3D solid models are far superior to 2D drawings for communicating design data to downstream engineering and manufacturing functions. Solid models contain all the surface and volumetric information needed to conduct engineering analysis and manufacturing processes – there is no need to re-create data to take advantage of advanced CAE analysis, automated NC toolpath generation, or rapid prototyping technologies. Furthermore, solid models

provide detailed, unambiguous visualization that helps eliminate errors to further reduce turnaround times for analysis, tooling, fabrication, production, and assembly.

Case study. Subsea Ventures, a leading provider of offshore drilling equipment, moved to solid modeling with the goal of reducing cycle time, and also to facilitate the use of structural analysis in the design process. When Subsea used 2D CAD, an

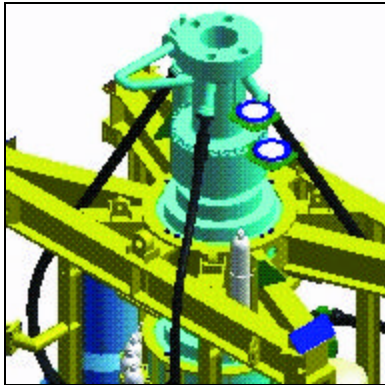

outside analyst would work from drawings to recreate components in 3D for analysis. Solid models eliminate that step by providing the 3D geometry for analysis models. To bring analysis in-house, Subsea purchased

Cosmos/Edge, a structural analysis program that operates within the Solid Edge environment. "Reducing cycle time is the main reason we moved from 2D CAD to solid modeling, says Frank Mooney, senior designer at Subsea Ventures Inc. "But since we found how easy it was to bring analysis into the design process, we've also begun to optimize our products to a much greater extent."

Case study. CTS, a major supplier of electronic and electrical components to the automotive industry,



produces many injection molded components. Consequently, creating proper molds is one of the major challenges in ramping up production of a new design. Design engineer Warren Williams says that since moving from 2D design to Solid

Edge, CTS now sends designs to mold makers in native Parasolid solid geometry format. There is zero data loss and no need to discuss markings on

drawings. Williams estimates Solid Edge has helped them produce molds 50% faster.

3D design data is useful throughout the enterprise

The 3D data generated in solid modeling-based product development can be applied far beyond design, engineering and manufacturing to many other enterprise functions. Unlike 2D drawings, solid models can be used intuitively wherever there is a need to communicate product information. Support and service organizations can use solid model data to enhance communication with customers. Field service personnel can use solid models to assist in troubleshooting and repair. Purchasing can use models to ensure clarity of communication and reduce errors in dealing with suppliers. Marketing can even use solid models in promotional efforts. With a broad spectrum of potential applications, 3D solid modeling-based design has much greater corollary benefit than 2D engineering drawings.

Case study. Med-Eng Systems, the world's leading developer of personal protection systems for bomb disposal and mine clearance technicians, recently moved from 2D AutoCAD to Solid Edge. The move into 3D has created excitement throughout the company. Marketing

Coordinator John Carson calls Solid Edge "a very useful marketing tool." Colorful 3D models help promote products by visually communicating the high-tech nature of Med-Eng's innovative designs to non-technical customers. Carson is



also excited by the upcoming multimedia CD-ROM of Solid Edge models that will allow customers to see Med-Eng's products from any perspective, an important selling feature to people whose lives depend upon 360 degree protection. In the future, the Marketing department plans to use 3D models on their website so potential customers can suggest improvements to new designs before they are finalized and sent to production.

Cost justification for moving to 3D solid modeling

Even if the benefits of moving from 2D to 3D CAD are well documented, most companies require some formal cost-benefit analysis to justify the investment in 3D design tools. Below are some return-on-investment examples that can help sell the bottom-line advantages of 3D CAD expenditures.

Labor cost reductions: design and drafting productivity gains

With the streamlined 3D solid modeling techniques in Solid Edge, manufacturers typically realize a 4 to 1 productivity increase in part design and drafting, as compared to using 2D CAD for the same tasks. Companies can readily calculate annual design and drafting direct labor savings with the following formula:

Burdened hourly engineering salary x Number of hours per year x Percentage of engineer's time using CAD systems x Typical 3D cycle time reduction = CAD labor cost savings per year

Example:

- 4 people @ \$30/hour
- 7,680 total man-hours per year
- 85% of time utilized on CAD system
- 4:1 productivity gain = 75% savings

$\$30 \times 7,680 \times 85\% \times 75\% = \$146,880$ direct annual labor savings

Quality cost reductions: reduced errors

Solid Edge's 3D solid modeling and automated associative drafting eliminate the vast majority of design and drafting errors. This directly reduces the number of engineering change orders (ECOs) companies must process through the product development cycle. With correct-by-design virtual models of assemblies, designers can eliminate most assembly fit and interference errors in the earliest stages of the design. In addition, most drawing errors are eliminated because drawing views actually reference the 3D solid model and do not need to be changed individually when changes are made to the design model. Typically, companies can eliminate

90% of the ECOs attributable to design and drafting errors.

Companies can calculate their annual cost savings from reduced ECOs using the following formula:

Number of ECOs per year attributable to design and drafting errors x Average hours per ECO x Hourly salary x Percent reduction in number of ECOs = Annual cost savings from reduced ECOs

Example:

- Design error ECOs (25) + Drafting error ECOs (30)
- 30 hours per ECO
- \$30/hour
- 90% typical reduction

$55 \times 30 \times 30 \times 90\% = \$44,550$ annual savings from eliminated ECOs

Other quality savings

Many other downstream savings are attributable to the enhanced quality that 3D design affords manufacturers. These can be included in the cost justification where quantifiable, and include:

- Reduced tooling costs due to more accurate and complete information
- Reduced scrap
- Reduced inspection manpower
- Reduced development test reruns

Rework & warranty savings: Reduction of rework, reduced reliance on physical prototyping

Unigraphics Solutions has found that almost all form, fit and function problems can be found through virtual assembly modeling, prior to actually building prototypes. The ability to solve problems early in the design cycle using solid modeling techniques yields direct cost savings, both through reduced errors and rework and through fewer prototypes.

In calculating the cost savings, most companies can assume that 3D design will yield a 50% reduction in both rework costs and in costs associated with physical prototyping.

Technical publication savings: reduction of production time

Companies that produce technical publications with many product illustrations like isometric and exploded views can realize significant savings by using Solid Edge 3D models to automatically create the graphics. Savings depend on the number of such publications, the number of illustrations, and their current creation costs.

Example:

- Number of technical publications per year = 20
- Average illustration time per publication = 40 hours
- Hourly burdened labor cost = \$30
- Typical reduction in illustration time = 50%

$20 \times 40 \times \$30 \times 50\% = \$12,000$ annual savings

Time to market benefits of 3D design

Time to market is critical to the business success of all manufacturing companies. Market share, sales volume and revenues are increased because the first to market with a unique product captures the lion's share of sales. While difficult to quantify, it is possible to attribute some time to market value to 3D design technology. Product development time is reduced with faster design and drafting, as well as other downstream benefits such as fewer design errors and prototypes. The first to market with a unique product can also count larger margins before competitive pressures force downward pricing.

Product innovation benefits

Three-dimensional CAD technology allows designers to produce and evaluate more design iterations, which increases the degree of innovation in products. To account for this in 3D CAD justification, companies can estimate the number of new products or design projects that can be completed each year. This can be translated into more product lines introduced and thus will be included in the time-to-market benefits estimate.



**For More Information, Call
Your Solid Edge Reseller:**

Unigraphics Solutions International Headquarters

Americas

13736 Riverport Drive
Maryland Heights, MO 63043
USA
(800) 498-5351

Europe

Centrum House
101-103 Fleet Road
GU13 8NZ
UK
+31 (0) 79363 5515

Asia Pacific

Suite 1701
Cheung Kong Center
2 Queen's Road Central
HONG KONG
(852) 2230-3333

Other Areas

(256) 705-2600



800-807-2200

www.solid-edge.com

solidedge@ugsolutions.com