



SOLID EDGE

Solid Edge: Design it right the first time

Solid Edge, the leading mid-range CAD software from UGS, helps mechanical design professionals get to market faster by designing products right the first time. More than a modeling and drafting package, Solid Edge delivers unique tools for eliminating design errors, so you can reduce development time and decrease costs. When you design with Solid Edge, you not only create 3D virtual prototypes of your products, you also capture knowledge that guides the engineering process toward an error-free, accurate design solution.

The uniquely productive tools in Solid Edge are remarkably affordable and easy to use, to help you realize the business benefits of advanced 3D mechanical design technology:

Faster response. With Solid Edge's innovative tools, you can respond to customer specifications more quickly with new designs and alternative design solutions. Solid models clearly communicate your proposed designs, and correct Bills of Material from CAD models help improve the accuracy of proposals.

Greater design productivity and throughput. With Solid Edge, your design team can get more work done with less effort. Your designers will readily master advanced 3D CAD solid modeling techniques without a long and expensive learning curve. Streamlined design operations with an intuitive user interface make Solid Edge the most productive CAD system available, requiring fewer commands and mouse clicks to get the job done. The added productivity results in significant labor and time savings.

Shorter design, manufacturing, and delivery cycles. Solid Edge's productivity edge automates and streamlines all design functions, from concept layout through detail design and drafting, to significantly reduce development time. With integrated applications for analysis, manufacturing, and data management, Solid Edge supports full-cycle efficiencies that get you to market faster with higher-quality, lower-cost products.

Reduced product development costs. With the lowest cost of ownership of any 3D CAD system, Solid Edge gives you an up-front advantage in your outlay for design technology. In addition to labor and time savings, Solid Edge helps reduce costs associated with prototyping, errors and revisions, and engineering change orders.

Fewer errors and design revisions. With Solid Edge, you build accurate virtual models with embedded engineering knowledge that helps you avoid costly errors, scrap, and rework. You can detect and eliminate fit and function problems long before they reach the shop floor, and reduce errors and changes from customers and suppliers with 3D design communication.

Improved quality, function, and reliability. The engineering aids in Solid Edge help you evaluate more design alternatives in less time, so you can optimize performance and reliability. Solid Edge includes mass properties calculations, design sensors, motion analysis, interference detection, and other built-in tools to help you capture and apply your design knowledge as you develop the CAD model.

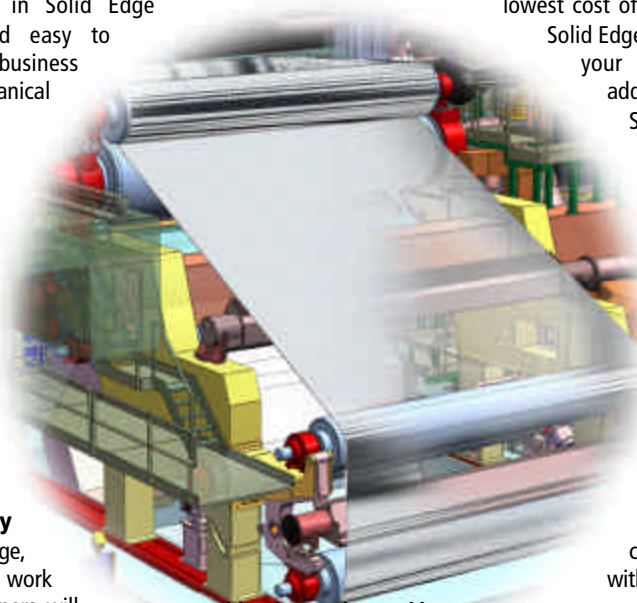

Vorth Sulzer Papiermaschinen GmbH & Co KG



By building the machine digitally using the software's assembly modeling capability, we knew everything would fit. That was much more efficient than tearing apart a prototype to make it work.



– Steve Cook, Vice-president, Dayton Systems Group



Unsurpassed assembly productivity

Solid Edge easily tackles large assembly models that are fundamental to mechanical design. Supporting both top-down and bottom-up techniques, Solid Edge enables you to divide design tasks among team members, release subassemblies as they are completed, and ensure that the final product comes together smoothly. You can ensure accurate fit of parts by designing them within the assembly model, directly using geometry from adjacent parts or layouts. To reduce assembly modeling time, designers can "teach" parts to automatically snap into position with proper mating and alignment relationships.

Solid Edge optimizes interactive assembly performance to help you explore more design alternatives in less time. You can quickly and easily restructure assemblies, create families of assemblies to evaluate different product configurations, and model assemblies with moving parts in their alternate positions.

With built-in assembly management tools, Solid Edge reduces the time you spend managing design data. Integrated parts libraries and revision aids help you quickly find, replace, and revise assembly components. Lightweight and simplified part representations make it easy and practical to work with assemblies comprising thousands of parts.

Eliminate errors with engineering aids

Solid Edge supports the iterative engineering process with unique design aids that help eliminate errors and assist in making decisions. These exclusive tools help you capture knowledge as you refine the design, and automatically preserve the design intent when you make changes.

Design rule sensors. DesignAssistant sensors, analogous to physical sensing devices, are innovative Solid Edge design tools that provide continuing feedback on engineering rules and variables as the design develops. With sensors, designers can

capture and apply design rules and criteria, automatically monitoring distances between components, surface areas, physical properties, and other design variables while refining the product model.

Motion analysis. Solid Edge includes a built-in motion analysis package, Simply Motion, developed by Mechanical Dynamics Inc. Simply Motion automatically builds analysis models that capture motion intelligence directly from Solid Edge assemblies. Designers can quickly and accurately simulate complex movement, detect interferences and create animations of the full range of assembly motion. This analytical feedback helps identify and correct problems and improves the quality and performance of assemblies with moving parts.

On-line engineering reference. The Engineering Handbook is an integrated add-on package for Solid Edge that provides on-line reference and automatic mechanical part modeling. Developed by MechSoft.com, Inc., the handbook includes calculations representing standard mathematical formulas and physical theories for a broad range of components. A calculation-driven parts generator automatically builds part models from the engineering calculations, based on desired load and service criteria. Also included is a complete on-line reference that documents algorithms, formulas and theories.

Drawing change tracker. Solid Edge provides an innovative utility that tracks changes in engineering drawings that result from alterations of the 3D design model. The drawing tracker gives designers detailed feedback through prominent visual cues that signal when drawing views and annotations are out of date. Instructions for updating the drawing links and the model are also provided to direct the designers in finding and amending potential drawing errors. The direct benefit is quicker detection and correction of drawing errors, without manual checking.



Solid Edge gives us everything we need for machinery design, at a fraction of the cost of high-end systems.

— Paul Choate
Engineering Manager
Alcoa Packaging Machinery

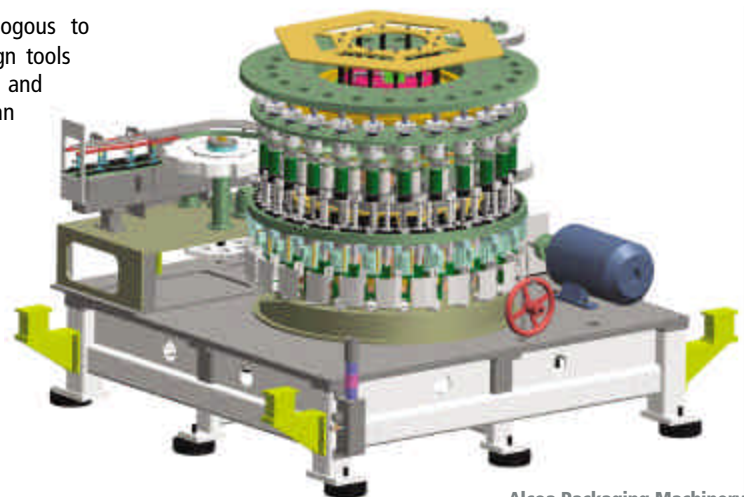

Alcoa Packaging Machinery

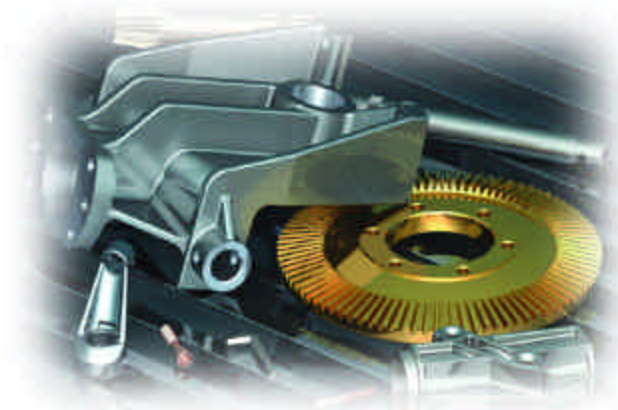

Fella-Werke GmbH & Co. KG

Model faster with process knowledge

Solid Edge helps engineers design more rapidly with parametric, feature-based tools that model mechanical parts more efficiently than other CAD systems. Beginning with basic part shapes created from revolved or extruded sketches, designers can easily add common mechanical features like holes, cutouts, protrusions, rounds, and thin-wall features, as well as more complex features like draft angles, sweeps, lofts, helical features and feature patterns. Part geometry, relationships, and dimensions can be changed quickly to investigate design alternatives.

Solid Edge further boosts design productivity with specialized environments for sheet metal, weldments, and tubing. These environments embody engineering process knowledge in tailored commands and structured workflows that help you design much more quickly than general-purpose CAD modeling tools.

Sheet metal. Solid Edge's sheet metal environment uses standard sheet metal and fabrication terminology, with streamlined modeling commands for tabs, flanges, louvers, dimples, cutouts, mitred corners, corner breaks, and other sheet metal-specific part features. With automated placement of bend relief, bend allowance calculations, and flat pattern development, Solid Edge delivers the most advanced sheet metal CAD package available.

Weldments. A customized command set in Solid Edge accelerates design of weldments. The weldment environment assists in defining the constituent parts of weldments, as well as weld beads, pre-weld surface treatments, and machining operations after the welds are applied. Solid Edge documents the entire weldment manufacturing process, with component drawings as well as pre-weld and post-machining views. Weldment designs can be placed and manipulated as single components in machinery models.

Tubing. Solid Edge XpresRoute is an integrated add-on package that rapidly routes and models tubing for hydraulic or pneumatic systems. The XpresRoute module helps you quickly define the 3D tube properties and paths between assembly components. After defining these parameters, you can automatically create a 3D solid model of the tube part, complete with end treatments. Tubing parts are dynamically associative to the components they connect, so that they automatically adjust when changes are made in related parts.

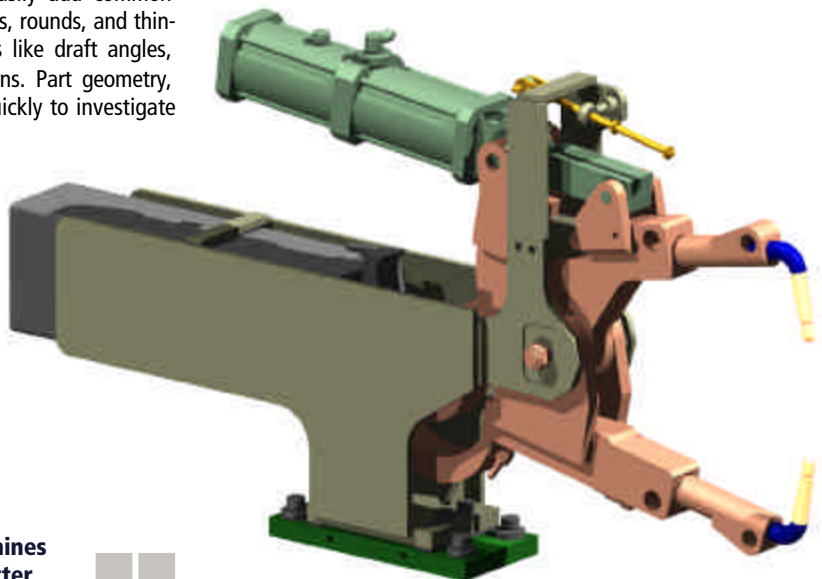

We're not only designing machines faster, we're making them better.

— Alan D. Flores II
Mechanical Design Engineer
Casa Herrera





Solid Edge has reduced design time for new products an average of between 30 and 50 percent and in some cases as much as 70 percent.



– John Allison, CAD Manager, FASCO Motors Group

Streamlined drafting

Developed specifically for mechanical drawing production, Solid Edge provides excellent drawing layout, detailing, annotation, and dimensioning controls that automatically comply with the mechanical drafting standard you select. Whether you are working from a solid part, an assembly model, or a blank drawing sheet, Solid Edge drafting and detailing tools help complete your drawings more rapidly and easily than any other CAD system.

Solid Edge's associative drafting system automatically creates and updates drawings from 3D models. When creating any initial drawing view, the Drawing View Creation Wizard captures process knowledge of drawing preparation and assists in drawing view placement. Designers simply select the model and then select and arrange views on the sheet to create the drawing graphics. Solid Edge quickly creates standard and auxiliary views, including section, detail, and isometric views. As changes are made to models, associated drawings update automatically to reflect the changes. The drafting system in Solid Edge dramatically accelerates assembly drawing by automatically creating exploded views, balloons, parts lists, and Bills of Material.

Practical design collaboration

With Solid Edge, manufacturers can improve design data sharing and collaboration with practical, inexpensive tools. SmartView is a free viewer for Solid Edge design files that works independently of the CAD software, enabling anyone in the enterprise or supply chain to view drawings or part and assembly models. To leverage company intranets, extranets or the Internet for design communication, Solid Edge Web Publisher provides a fast and easy method for publishing web pages with Solid Edge 3D models, Bills of Material, and related data. This integrated module works directly from the Solid Edge design session using a simple wizard interface that requires no web publishing expertise. Published models can be viewed on the web with the Microsoft Internet Explorer browser, and users can manipulate the display of the model and even manually create exploded assembly views. Web Publisher is an inexpensive solution for creating web-ready spare parts catalogs or engineer-to-order applications for customers.

For real-time collaborative design, Solid Edge uses industry-standard visualization and collaboration technologies from UGS. These products and services include Solid Edge Exchange, a hosted site where design teams, customers, and suppliers can establish collaborative projects, organize, share, and manage data, and concurrently access, review, and mark up engineering design models.



It was clear to us that Solid Edge would provide a higher level of productivity and return on investment than the other systems we evaluated. We were also very impressed with Solid Edge's ease-of-use.



*– J.Y. Yoo
Automation R&D Manager
Sun Yang Tech*

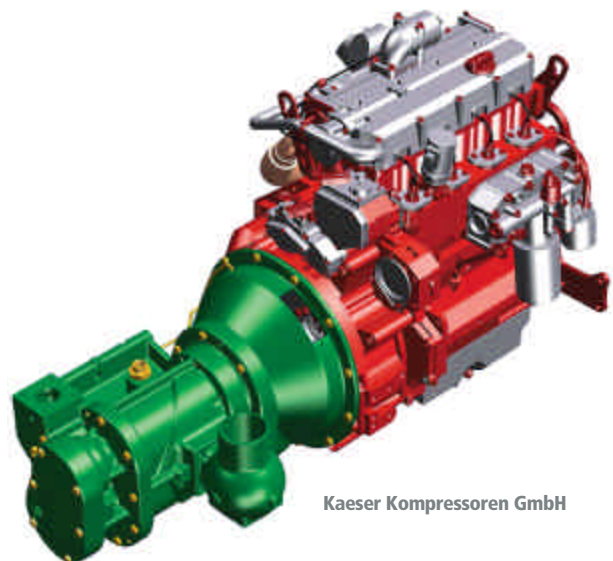

Kaeser Kompressoren GmbH

The 3D advantage

Many mechanical engineers are still using design processes based on 2D engineering drawings, even if they acknowledge the business and productivity benefits of 3D design. Solid Edge removes the roadblocks to 3D by making the migration significantly less expensive and less difficult.

Solid Edge delivers advanced 3D CAD in the industry's most intuitive Windows-based interface, so it is remarkably easy to learn and use. Patented STREAM technology employs inference logic and decision management techniques to streamline operation and shorten the learning curve.

Dozens of built-in tutorials provide self-paced, step-by-step instruction and guidance as designers use the software. The on-line help system includes information for users moving from 2D CAD systems. With these tools, thousands of former 2D designers have become productive with Solid Edge within hours of installing the software.

With Solid Edge, designers who are moving from 2D need not abandon their legacy data or CAD knowledge. Solid Edge builds upon 2D design practices, and directly uses 2D CAD data in 3D modeling operations. Built-in translators provide simple, wizard-driven import and export of 2D designs in AutoCAD format.

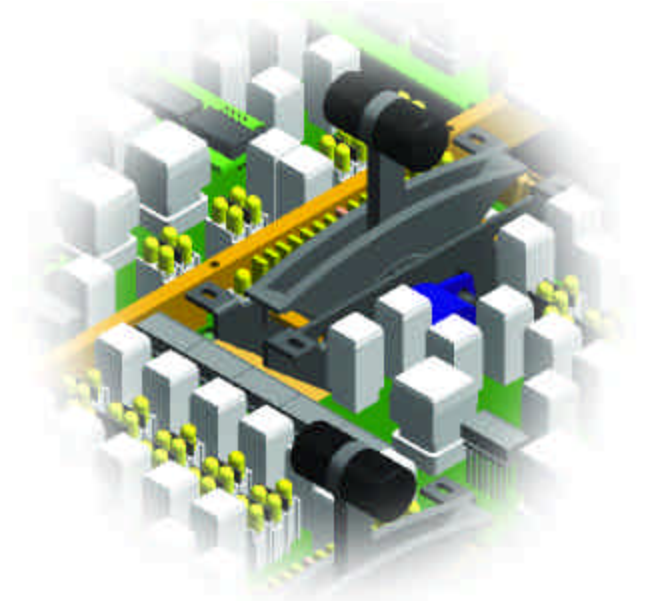

Philips Broadcast Systems



My time savings were substantial but they are insignificant compared to what I saved the client by delivering a design that was free of interferences.



*– Scott Christensen
President and Designer
Summit Tool Design*



EKM GmbH

Data exchange

Mechanical design teams can readily exchange CAD data with other systems using Solid Edge's built in data translation tools. These support two-way conversion of widely used CAD formats, including AutoCAD (DXF/DWG) and Pro/ENGINEER, the IGES and STEP neutral formats, and the Parasolid and ACIS kernel formats used by a host of CAD, CAM, and CAE software programs. An additional Feature Recognizer module is available to add parametric design intelligence to imported models.

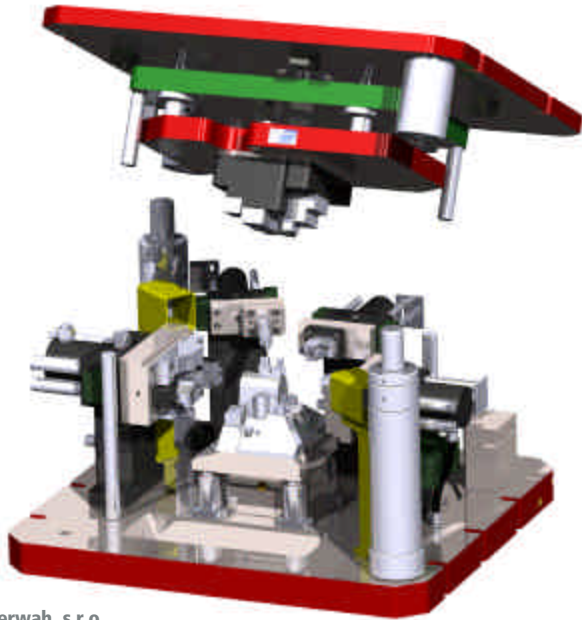

Gerwah, s.r.o.



Solid Edge was the easiest to use and contained the best capabilities to intelligently capture our design intent with efficient tubing design capability, industry-intuitive sheet metal design processes and a bill of materials output that will benefit our entire enterprise.



*– Young-Chal Kang
Director of Research and Development Center
Rinnai Korea Corporation*

Design-through-manufacturing automation

Solid Edge is the cornerstone of a full-cycle solution that helps transform mechanical designs into deliverable products faster and at lower cost. Working directly with leading CAE and CAM applications, Solid Edge provides all the design data needed to automate analysis and manufacturing. High-performance solutions are integrated with Solid Edge to eliminate redundant data creation and minimize delays between design, analysis, and production. Integrated tools for Solid Edge include:

- Analysis (FEA)
- Animation
- Consulting/Customization
- Design Tools
- Electro-Mechanical
- Graphics Cards
- Hardware
- Kinematics/Dynamics
- Manufacturing
- Mold Design Tools
- PDM/ERP
- Product Collaboration
- Publications
- Rapid Prototyping
- Reverse Engineering
- Sheetmetal Fabrication
- Standard Parts
- Surfacing
- Tolerance Analysis
- Translators
- Viewing/Render/Redline

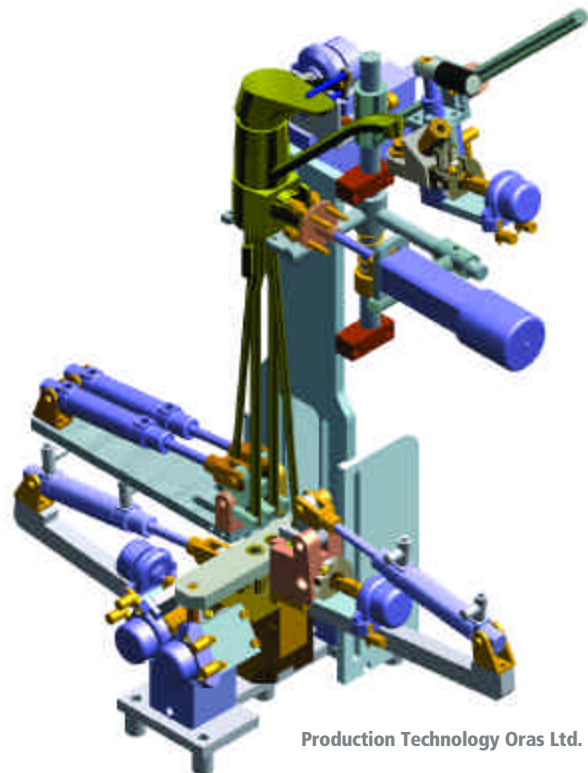

Production Technology Oras Ltd.

Visit www.solid-edge.com/voyager/default.htm for a current list of Voyager Program members.



SOLID EDGE

Backed by UGS – a world leader!

When you choose Solid Edge you join a team of expert resellers, product developers, technical support personnel, training professionals, and fellow users who work together to ensure that Solid Edge continues to deliver the most productive 3D mechanical CAD tools available. You can feel confident in your decision because a world leader backs Solid Edge and its customers.

UGS is one of the world's fastest growing and most successful software and services companies, dedicated to helping manufacturers optimize their product development processes. UGS' rich heritage and financial strength have been established by consistently providing the industry's best product development applications for over 25 years.

Today, UGS is distinguished as the leading supplier of Internet-based product life cycle collaboration solutions as well as the company that is creating the de facto industry standards for the digital product. With offices in over 30 countries around the globe, UGS is the vendor of choice for open solutions that seamlessly weave into any environment and create unprecedented value for the world's most demanding customers. In addition, UGS is the first company in its industry to earn the ISO 9001/TickIT certification.



powering
collaborative
commerce

www.solid-edge.com
solidedge@ugs.com

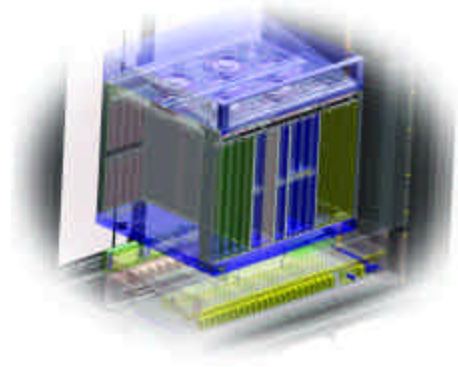

UGS International Headquarters

Americas

10824 Hope Street
Cypress, CA 90630
USA
(800) 498-5351

Europe

Norwich House
Knoll Road
Camberley, Surrey
UK
+31 (0) 79363 5515

Asia Pacific

Suite 1701
Cheung Kong Center
2 Queen's Road Central
HONG KONG
(852) 2230-3333

For more information, call your
Solid Edge Reseller: